

WPM® CRACK INDUCING WATERSTOP

ART.NR. 0004-250
02.04.2026

Waterproofing element for below-grade reinforced cast-in-place concrete structures that control and waterproofs concrete shrinkage cracks while maintaining the structure's strength properties.

PRODUCT DESCRIPTION:

The WPM® CRACK INDUCING WATERSTOP is a keyway-shaped galvanized steel sheet waterproofing element for below-grade reinforced concrete structures that consists of 3 components:

1. Galvanized steel sheet - 150mm wide with a special polymer coating that provides a waterproof connection with concrete.
2. 2x Z-shaped galvanized steel plates with a width of 50mm, 80mm, or 100mm, depending on the structure's thickness.

The waterproofing element is installed between the reinforcement rebars within a calculated distance from each other before the casting process. The Z-shaped steel plates connected perpendicularly to the galvanized steel sheet give the controlled shrinkage crack a binding keyway shape that maintains the structure's strength properties.

The product is protected by valid patents in the United Arab Emirates, the United States, and Estonia; in March 2026, a patent was also registered in Ukraine, and the European patent is pending.

ENVIRONMENTAL DECLARATION:

EPD Certificate Number: RTS_283_24

AREA OF APPLICATION:

The WPM® CRACK INDUCING WATERSTOP is used in below-grade cast-in-place concrete structures between the reinforcement steel in the wall and the floor slab to make a controlled and watertight binding keyway-shaped shrinkage crack. The element is installed between the reinforcement rebars at a calculated distance depending on the design.

PROPERTIES:

- Controlled and waterproofed pre-defined shrinkage crack point
- Load-bearing watertight binding keyway-shaped shrinkage crack
- Special coating, highly elastic, not reactive with water
- The polymer coating turns homogeneous with concrete
- Watertight against pressurized water up to 24 m (2.4 bar), officially tested at TalTech University - N° 372-A/19
- Tested for water pressure up to 15 bar - test protocol no.1/2024
- Made in Estonia

SPECIFICATIONS:

- Steel material: galvanized steel
- Steel sheet width: 150 mm
- Steel sheet length: 2,5 m
- Steel sheet thickness: 0,7 mm
- Coating: polymer coating
- Thickness of the complete sheet: approx. 1,7 mm
- Color:
 - Polymer coating: dark grey
 - Galvanized steel sheet: silver
- Z-shaped galvanized steel sheet: 50, 60, 80, 100 mm
- Temperature resistance: -35°C - +75°C
- Working temperature: no limits

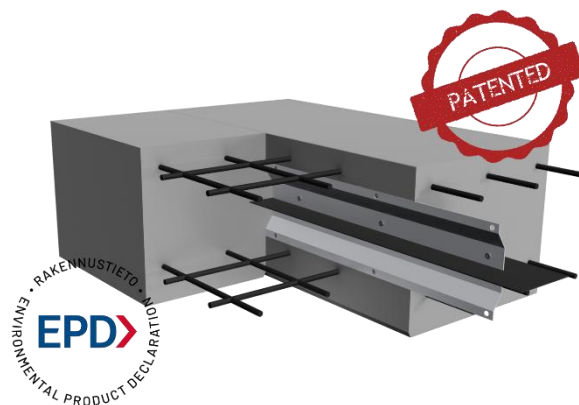



CHARACTERISTICS AND ADVANTAGES:

- Easy to install, up to 80% installation labor savings over traditional waterproofing
- Retains structure's strength properties (due to binding keyway-shaped shrinkage crack form, weakens < 10%)
- Can be designed for load-bearing structures
- Waterproofs designed shrinkage cracks
- Makes it safe to pour large amounts of concrete at once
- Special polymer coating does not react with water
- Turns homogeneous with concrete – more watertight seal!
- Can be used in cooperation with other types of waterstops
- Life expectancy in the structure - structures lifetime
- Simple design and easy installation reduce potential installation errors

PACKAGE:

6 x 2,5 m main detail, 12 x Z-shaped metal sheet details, 12x joint clips, 60x metal screws.

STORAGE:

36 months in cool and dry conditions with the original package

INSTALLATION:

The element is installed between the reinforcement rebars at a distance depending on the dimensions of the structure. To connect elements, apply a glue stripe in the middle of the 10 cm overlap and fix it with clips. Use a binding wire to fix the element between the reinforcement rebars.

The elements are installed at a calculated distance, depending on the dimensions of the concrete structure. Then, a triangular chamfer profile must be installed on both or one of the inner sides of the formwork, which depends on the design. Chamfer profile marks and finishes the location of the shrinkage crack.

All WPM® waterproofing elements together in a system create an uninterrupted connection between all construction joints and controlled shrinkage cracks in the reinforced concrete structure.

**) Alternative joint connection without glue – The overlap of waterstop ends can also be installed without glue if the waterstop is placed before the concrete cast. Ensure that the ends to be connected are clean, place them tightly on top of each other, and secure the connection with clamps. If necessary, screws may also be used, but they must be installed only at the outer edge of the waterstop!*

RECOMMENDED TOOLS:

Connecting clips, binding wire, binding hook, screwdriver (battery drill), and metal screws.

SAFETY:

Wear gloves and other personal protective equipment when handling and installing the product.

USE IN FOUNDATION SLAB AND CEILING SLAB:

NB! The installation steps given are recommended, and the actual installation distances may differ from the recommended ones.

The installation location and distance of the profiles depend on the shape of the foundation and ceiling slab. Also, the structure's thickness and the reinforcement bars' diameter used.

The recommended maximum installation step for the profiles is as follows:

On the lower side of the foundation slab, it is recommended to install a triangular chamfer element in the same place as the profile

(eg30x30x43 mm in the foundation slab and 15x15x21 mm in the ceiling slab) to facilitate the formation of a crack at the desired location.

The information given on the product page is based on and corresponds to the available information. The warranty covers the materials and does not extend to their incorrect installation and intended use. It is the user's responsibility to assess the material's suitability for the place of use. In case of doubt, it is necessary to carry out trial tests or ask for advice from the manufacturer.



WPM® Crack Inducing Waterstop in foundation slab:

WPM® Crack Inducing Waterstop in ceiling slab:

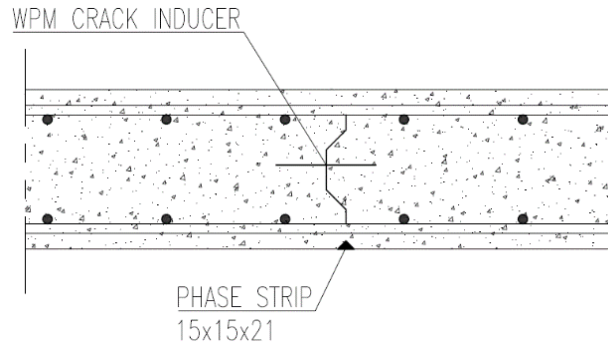
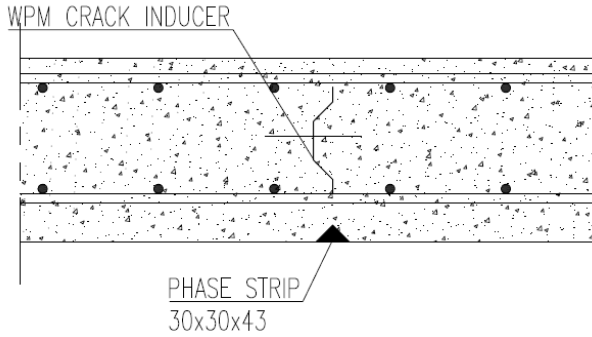

USE IN WALLS:

To use the WPM® Crack Inducing Waterstop in walls, we have created a [3D Automatic Crack Inducer Calculator](#), which shows the exact locations of the crack-inducing element and other construction joint profiles in the structure along with the consumption of different materials.

In wall:

Picture: 3D Automatic Crack Inducer Calculator

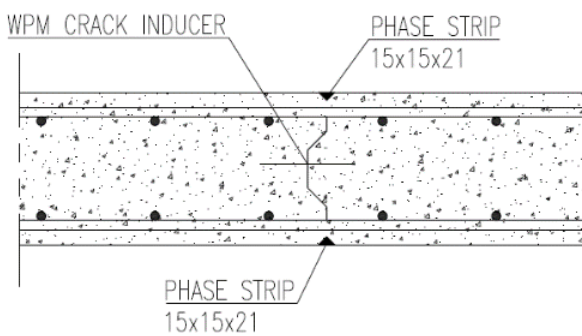
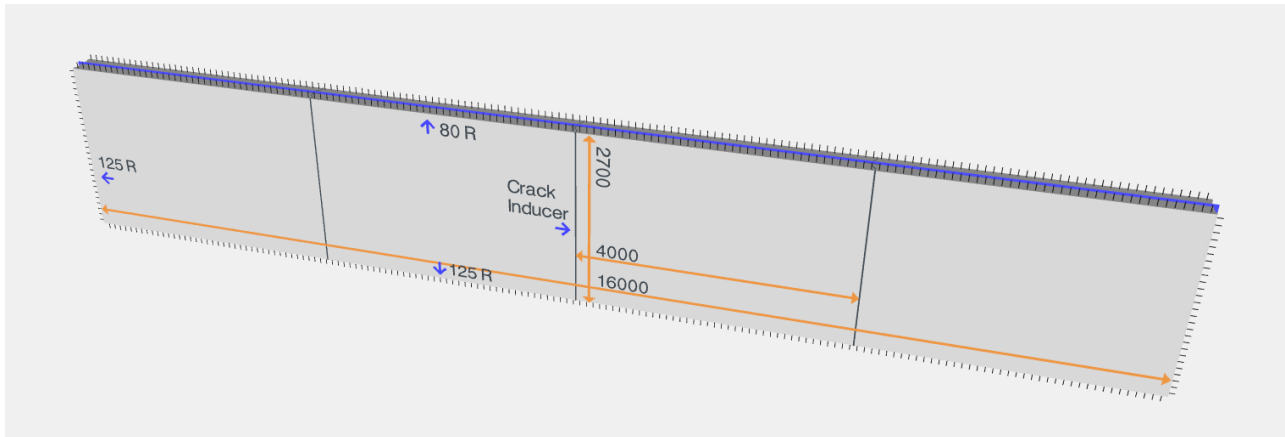

The information given on the product page is based on and corresponds to the available information. The warranty covers the materials and does not extend to their incorrect installation and intended use. It is the user's responsibility to assess the material's suitability for the place of use. In case of doubt, it is necessary to carry out trial tests or ask for advice from the manufacturer.



WPM® CRACK INDUCING WATERSTOP MEASUREMENTS:

Art.nr 0004-250-2x50	WPM® CRACK INDUCING WATERSTOP- 2x50 mm (20/15/15) 2,5 m
Art.nr 0004-250-2x60	WPM® CRACK INDUCING WATERSTOP- 2x60 mm (20/20/20) 2,5 m
Art.nr 0004-250-2x80	WPM® CRACK INDUCING WATERSTOP- 2x80 mm (20/40/20) 2,5 m
Art.nr 0004-250-2x100	WPM® CRACK INDUCING WATERSTOP- 2x100 mm (20/60/20) 2,5 m

The information given on the product page is based on and corresponds to the available information. The warranty covers the materials and does not extend to their incorrect installation and intended use. It is the user's responsibility to assess the material's suitability for the place of use. In case of doubt, it is necessary to carry out trial tests or ask for advice from the manufacturer.