



## PRIMOSTAR® CRACK CONTROL SYSTEM (roll)

ART.NR. 000

13.05.2026

Reinforced concrete waterproofing element that controls and waterproofs shrinkage cracks without weakening the structure.

### PRODUCT DESCRIPTION:

Primostar® Crack Control System in roll is an element made of galvanized steel sheets that creates a controlled shrinkage crack in reinforced concrete structures. The element consists of a waterstop component and attached sheet metal parts, which can be selected according to the thickness of the structure.

The element is installed between reinforcing bars before concrete pouring, at a specifically calculated spacing. The crack-inducing parts, formed from components connected perpendicular to galvanized polymer-coated steel sheets, give the shrinkage crack a stepped shape, helping to preserve the structural strength of the construction.

### ENVIRONMENTAL DECLARATION:

EPD Certificate number: RTS\_283\_24

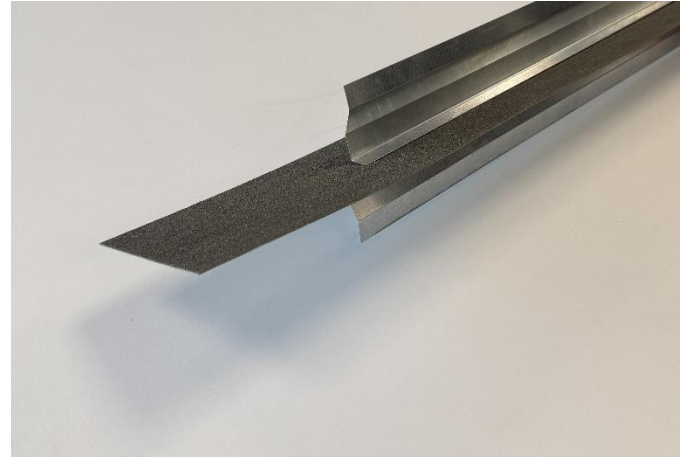

### AREA OF APPLICATION:

Primostar® Crack Control System is used to control shrinkage cracks and provide waterproofing in reinforced monolithic concrete structures. The element is installed between reinforcement bars at a specifically calculated spacing, depending on the structure.

### PROPERTIES:

- Creates a controlled shrinkage crack at a predetermined location
- Watertight, load-bearing shrinkage crack that does not weaken the structure
- Modular, suitable for use in structures of different thicknesses
- Special polymer coating, highly elastic, non-reactive with water
- Polymer coating forms a homogenous bond when curing in contact with concrete
- Ensures watertightness up to 24m (2.4 bar), officially tested at TalTech University – Test No. 372-A/19
- Tested for watertightness up to 15 bar – Test Protocol No. 1/2024
- Made in Estonia

### SPECIFICATIONS:

- Steel sheet: galvanized steel
- Steel sheet width: 125 mm
- Element length: up to 15m
- Steel sheet thickness: 0,7 mm
- Coating: elastic polymer coating
- Steel sheet thickness with mineral coating: approx. 1.2mm
- Color:
  - Polymer coating: dark gray
  - Galvanized steel sheet: silver
- Formed sheet metal parts thickness: 0.5mm, length approx. 2.2m
- Width according to structure's thickness
- Temperature resistance: -35°C - +75°C
- Installation temperature: no restrictions

### CHARACTERISTICS AND ADVANTAGES:

- Easy to install: the convenient fastening system allows use with structures of different thicknesses
- The waterstop element is a single piece, meaning fewer joints and a lower risk of leaks
- Maintains the structural strength properties (the stepped shrinkage crack absorbs the resulting shear forces)
- Can be used in load-bearing structures

The information given on the product page is based on and corresponds to the available information. The warranty covers the materials and does not extend to their incorrect installation and intended use. It is the user's responsibility to assess the material's suitability for the place of use. In case of doubt, it is necessary to carry out trial tests or ask for advice from the manufacturer.



- Ensures a watertight, predefined, and controlled shrinkage crack
- Allows large-scale concrete structures to be poured quickly
- The special polymer coating does not react with water before or during installation
- The polymer coating becomes homogeneous when curing in contact with concrete – providing a more watertight connection
- Can be used with various construction joint profiles
- Expected service life in the structure – the entire lifespan of the construction
- Simple profile design and installation process reduce the potential installation errors
- Saves significant space during transport and storage

#### PACKAGE:

15m roll + flanges according to selection

#### STORAGE:

36 months in cool and dry conditions with the original package

#### INSTALLATION:

Since the structures have varying thicknesses, the panels are manufactured according to pre-ordered dimensions.

The installation of the profile is quick and simple thanks to a smart, integrated solution.

##### 1. Unroll the profile

The main part of the profile is supplied in a roll. During installation, unroll the element to the desired length.

##### 2. Bend the fasteners upright

The fasteners attached to the main element must be bent upright by hand – they form clamps for securing the panel.

##### 3. Install the panel

The panel is fixed under every second fastener (clamp).

Then secure the panel with a couple of screws to ensure the stability of the profile.

##### 4. Repeat on the other side

The panel is fixed under every second fastener (clamp).

Then secure the panel with a couple of screws to ensure the stability of the profile.

##### 5. Finished solution

The profile is now ready to use.

The element is installed between reinforcement bars at a spacing determined by the structural dimensions. To connect elements with other construction joint profiles, install them with an overlap of 7–10 cm and secure with clamps from both the top and bottom. Use tying wire to fix the element between the reinforcement bars.

The element is installed at a calculated spacing depending on the dimensions of the concrete structure. When using the WPM® Crack Control System element, a triangular chamfer strip must be installed on one or both inner sides of the reinforcement cage (depending on the structure) to mark and finish the location of the shrinkage crack.

All WPM® watertight profiles create a continuous connection in reinforced concrete structures between all construction joints and controlled shrinkage cracks.

**NB!** Installation may vary depending on the application. In case of doubt, request additional information from the distributor. The coating on the joint sheet is resistant to many chemicals; if necessary, ask the distributor for more information

#### RECOMMENDED TOOLS:

Connection clamps, screws, binding wire.

#### SAFETY:

When handling the product, wear gloves and other personal protective equipment.

The information given on the product page is based on and corresponds to the available information. The warranty covers the materials and does not extend to their incorrect installation and intended use. It is the user's responsibility to assess the material's suitability for the place of use. In case of doubt, it is necessary to carry out trial tests or ask for advice from the manufacturer.



## USE IN FOUNDATION SLAB AND CEILING SLAB:

**NB! The installation steps provided below are recommendations, and the actual installation process may differ from the suggested steps.**

The installation steps for the profiles depends on the shape of the foundation slab and ceiling slab, the thickness of the structure, and the diameter of the reinforcement bars used

A triangular chamfer strip should be installed on the bottom side of the foundation slab and ceiling slab to mark and finish the location of the resulting shrinkage (e.g., 30x30x43 mm in the foundation slab or 15x15x21 mm in the ceiling slab)

**NB! When removing form work from the ceiling slab, it is necessary to follow good construction practices and not rush the process. Removing the formwork before 14 days have passed increases the risk of unwanted cracks forming.**

### WPM® Crack Inducing waterstop in foundation slab:

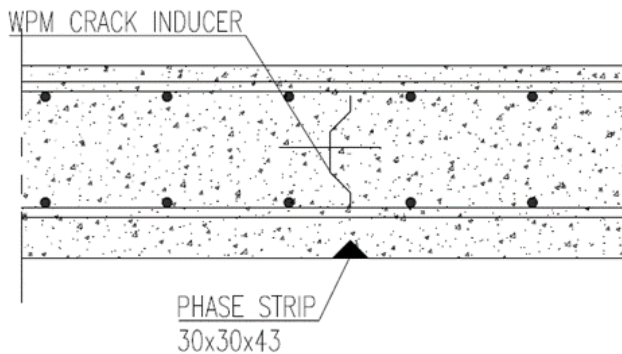

### WPM® Crack Inducing waterstop in ceiling slab:

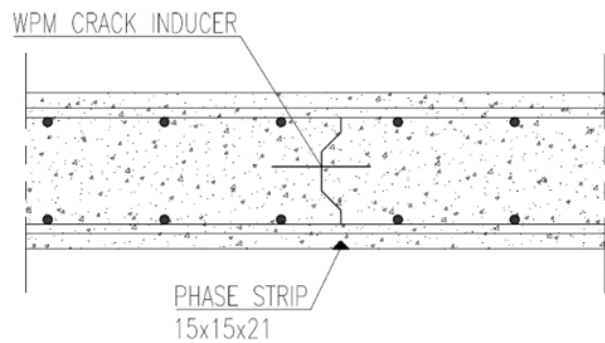

## USE IN WALLS:

For the use of WPM® Crack Inducing Waterstop in walls, we have created a [3D Automatic Crack Inducer Calculator -j](#), which shows the exact locations of the crack inducer and other construction joint profiles in the structure, along with the consumption of different materials.

In wall:

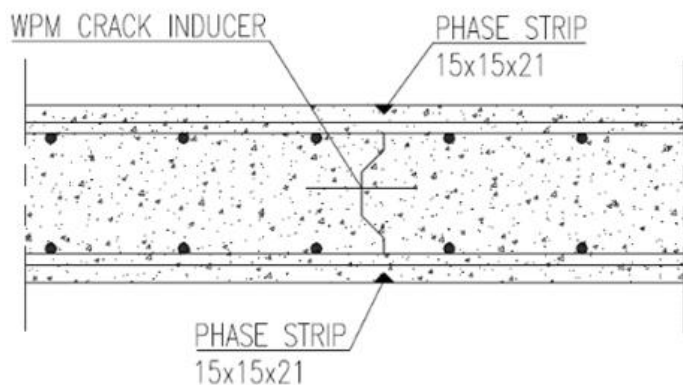

Photo: 3D Automatic Crack Inducer Calculator

The information given on the product page is based on and corresponds to the available information. The warranty covers the materials and does not extend to their incorrect installation and intended use. It is the user's responsibility to assess the material's suitability for the place of use. In case of doubt, it is necessary to carry out trial tests or ask for advice from the manufacturer.